

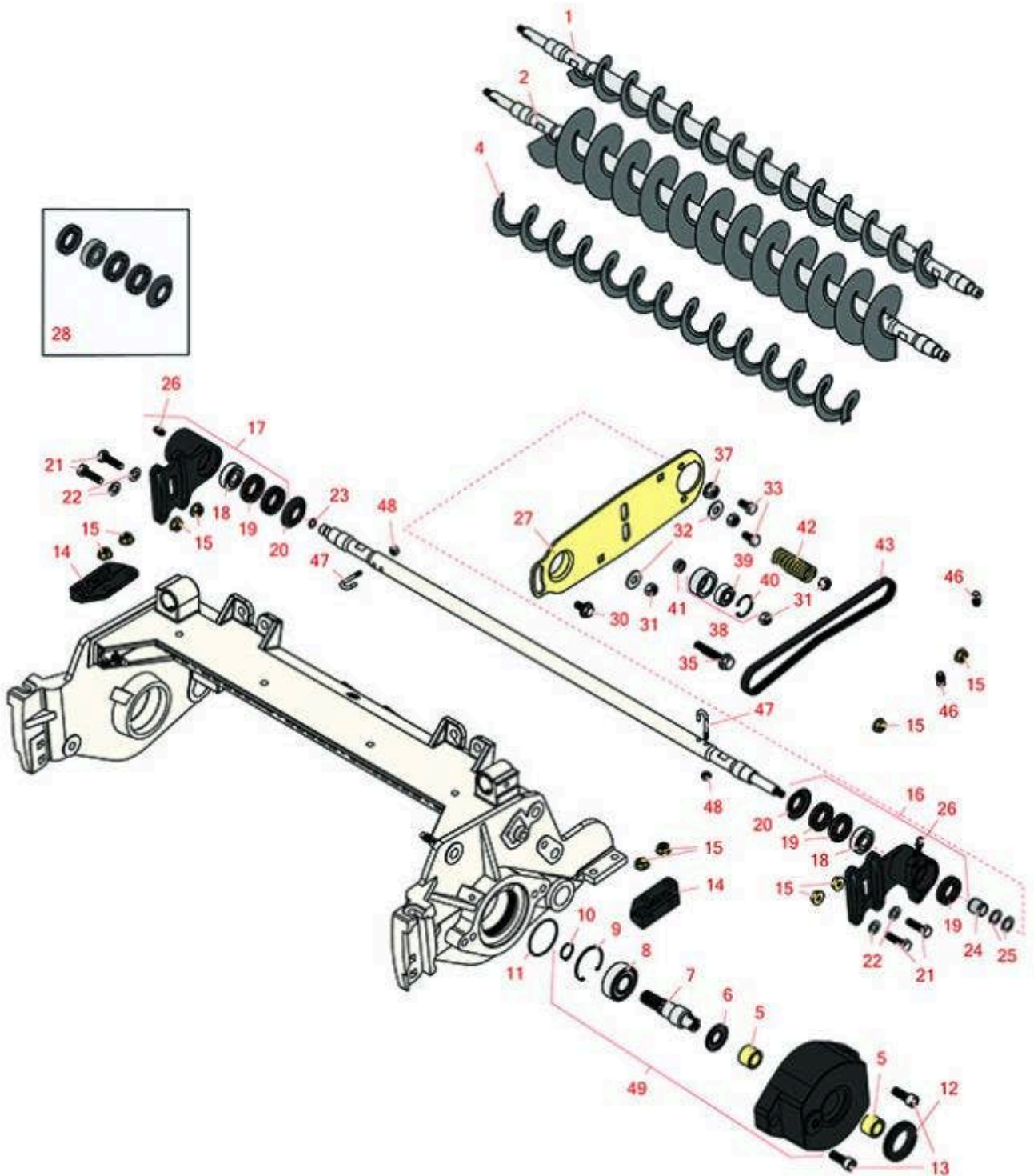

Replaces Toro Reelmaster 5510-G Parts

DPA Cutting Unit - Model 03696 & 03697

Rear Roller Brush



All original equipment manufacturers names and part numbers are used for identification purposes only, and we are in no way implying that our products are original equipment parts. Prices subject to change without notice.



Replaces Toro Reelmaster 5510-G Parts

DPA Cutting Unit - Model 03696 & 03697

Rear Roller Brush



Item No	R&R Part No.	OEM Part No.	Description	Qty Req	Order Quantity
Overhaul Kits					
28	R110-4086	110-4086	Kit - Bearing	1	
<i>Tech Note: Includes 1 ea: R95-0707 Bearing, R108-4172 Seal; & 3 ea: R106-8530 Seal:</i>					
Other Parts Available					
1	R150915	108-4190	Shaft Assy - Rear Roller Brush - 2 in Keyed	1	
<i>Tech Note: (2007 & Prior):</i>					
2	R150916		Shaft Assy - Rear Roller Brush 3.5 in - Keyed	1	
<i>Tech Note: (2007 & Prior):</i>					
3	R110-1740	110-1740	Brush-Roller (High HOC) 3.5 in OD	1	
4	R108-4193	108-4193	Brush - Roller - 2 OD	1	
5	R108-4477	108-4477	Spacer	1	
6	R107-7795	107-7795	Seal - Oil	1	
7	R108-4234	108-4234	Shaft - Drive	1	
8	R93-2559	93-2559	Bearing	1	
9	R32120-62	32120-62	Ring - Retaining	1	
10	R458013	30-0580, 32120-72, 458013, 93-2525, 936125	Ring - Retaining	1	
11	R112-6968	112-6968	O-Ring	1	
12	R240-7	240-7	Grommet - Rubber - 2 in OD	1	
13	R3274-7	3247-7, 3274-7	Bolt - Soc HD Cap 3/8-16 x 1	2	

All original equipment manufacturers names and part numbers are used for identification purposes only, and we are in no way implying that our products are original equipment parts. Prices subject to change without notice.



Replaces Toro Reelmaster 5510-G Parts

DPA Cutting Unit - Model 03696 & 03697

Rear Roller Brush



Item No	R&R Part No.	OEM Part No.	Description	Qty Req	Order Quantity
14	R108-4480	108-4480	Bracket - Rear Roller Brush	2	
15	R104-8300	104-8300, 104-8300, 119-4041	Locknut - 5/16-18 Flanged Y/Zinc	10	
16	R108-4495	108-4495	Bearing Housing Assy - Driven	1	
17	R108-4496	108-4496	Bearing Housing Assy - Non Driven	1	
18	R95-0707	95-0707	Bearing - Self Aligning	2	
19	R106-8530	106-8530	Seal - Oil	5	
20	R108-4172	108-4172	Seal - Excluder	2	
21	R322-16	322-16, Apr-00	Bolt - Hex HD 5/16-18 x 1-1/8	4	
22	R94-6936	94-6936, 94-9236	Washer - Hardened - 5/16 SAE	4	
23	R237-22	107-8844, 237-22, 237-78	O-Ring	1	
24	R108-4491	108-4491	Spacer - Hardened	1	
25	R112-6957	112-6957	Washer - Hardened	2	
26	R302-5	21-6010, 302-11, 302-37, 302-47, 302-5, 302-57, 302-58, 302-6, 31-0300, 32-9660, 60-0800, 62-3880, 92-4181	Fitting - Grease	2	
27	R108-4205	108-4205	Plate Assy - Rear Roller Brush	1	

All original equipment manufacturers names and part numbers are used for identification purposes only, and we are in no way implying that our products are original equipment parts. Prices subject to change without notice.



Replaces Toro Reelmaster 5510-G Parts

DPA Cutting Unit - Model 03696 & 03697

Rear Roller Brush



Item No	R&R Part No.	OEM Part No.	Description	Qty Req	Order Quantity
30	R27-0411	27-0411	Bolt - Shoulder	1	
31	R3296-47	3296-47	Locknut - 5/16-18 Jam Nyloc	6	
32	R3256-45	3256-45	Washer - Flat .733 x .381 x .058 YZ	6	
33	R322-2	322-2, 513338P	Bolt - Hex HD 5/16-18 x 5/8	2	
35	R66-9302	3234-20, 66-9302	Screw - HHF, Whiz	1	
37	R104-8301	104-8301, 104-9301, 109-6658, 133-7570	Locknut - 3/8-16 Nylon Flanged	1	
38	R110-1745	110-1745	Bearing Assy - Idler	1	
39	R110-1701	110-1701	Bearing	1	
40	R32151-60	32151-60	Ring - Snap	1	
41	R93-3658	93-3658	Spacer - Hardened	1	
42	R115-0839	115-0839	Spring - Idler - SS	1	
43	R115-0833	115-0833	Belt- Brush 7 in	1	
46	R150690	108-0989	Screw - Set 1/4-20 x 1/4	6	
47	R105-9632	105-9632	Bolt - J	2	
48	R3296-2	32127-10, 3296-2, 9157404	Nut - #10 Lock	2	
49	R108-4201	108-4201	Bearing Housing Assy	1	

All original equipment manufacturers names and part numbers are used for identification purposes only, and we are in no way implying that our products are original equipment parts. Prices subject to change without notice.